

# *LaserMatrix<sup>®</sup>*

## *Floor Model Stacker*

*(Full Capacity Models LM1000A115 & LM2400A100)*

### *Operator's Guide*

Part No: 066-00452-02  
Rev. G

# COPYRIGHT © 1994, OUTPUT TECHNOLOGY CORPORATION

All rights reserved under the Berne Convention.

## TRADEMARKS

**LaserMatrix** is a registered trademark of Output Technology Corporation.

## PARTS AND SERVICE

Contact Output Technology Corporation for parts and service. Have the serial number of your printer and LaserMatrix Stacker handy so that we can serve you more quickly.

We suggest you use genuine Output Technology Corporation supplies and authorized service centers. Contact us at —

(509) 536-0468 (Voice) or (509) 533-1280 (Fax)

Output Technology maintains a Bulletin Board System (BBS) service. In the U.S.A., call (509) 533-1217 to access our BBS service for the very latest drivers, firmware, pricing, maintenance and troubleshooting aids, and application information. Also, you can contact us at —

FTP: [ftp.output.com/public/output](ftp://ftp.output.com/public/output)

WWW: <http://www.output.com>

## CONTENTS

Introduction .....	1	Setup .....	17
Paper & Label Requirements .....	2	Operation .....	20
Floor Model Stacker Specifications..	3	Maintenance .....	25
Unpacking & Installation .....	4	Troubleshooting .....	26
Assembly .....	7	Parts & Accessories .....	27

## INTRODUCTION

The LaserMatrix<sup>®</sup> Floor Model Stacker (Models LM1000A115 & LM2400A100) will stack up to one full box of printed forms from a LaserMatrix printer.

In the automatic mode, the stacker is controlled by the printer. When the printer prints, the stacker turns two pairs of floating helical coils which “refold” and then stack the fanfolded paper. The coils float up with the paper as the stack grows in height.

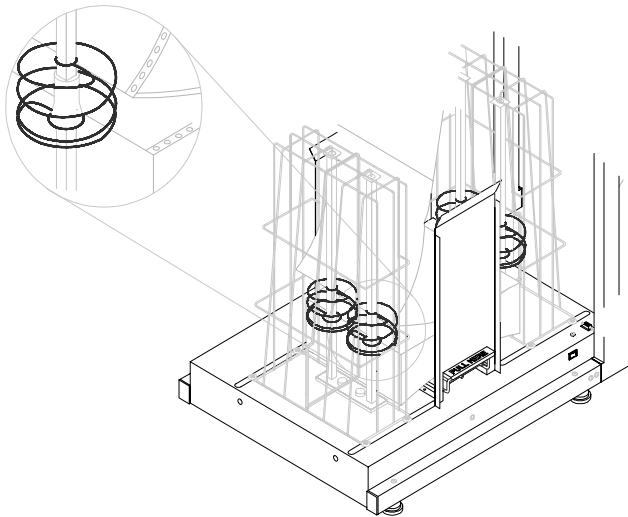

LB0-B1

The LaserMatrix Stacker solves a problem common to continuous form laser printers. The problem arises when a laser printer fuses toner to the paper. In the process, heat and pressure from the fuser iron out the perforations in the forms. The “ironed-out” forms are more difficult to refold and stack.

The LaserMatrix Floor Model Stacker allows you to reliably print large jobs *unattended* — up to one full box of paper. The stacker handles most grades of fanfolded paper and label stock made for a laser printer.

---

***NOTE:** Due to variations in manufacturing process, quality, and composition of forms, Output Technology cannot guarantee satisfactory performance with all forms. Forms should be tested to verify satisfactory performance prior to purchasing forms.*

---

The stacker also includes a convenient and stable platform for the printer itself.

## PAPER & LABEL REQUIREMENTS

<b>Paper Type:</b>	fanfold, single-part paper with a bond weight of 18 to 24 lb (65 to 90 g/m <sup>2</sup> ) and a caliper thickness of 3.2 to 4.5 mil (0.081 to 0.114 mm). Prefer 24 lb paper <u>without</u> laser (clear perf) perforations
<b>Label Type:</b>	fanfold labels with a caliper (thickness) not to exceed 7.5 mil (0.190 mm)
<b>Sheet Lengths:</b>	variable from 6 to 14 in. (approx. 152 to 355 mm), perf to perf
<b>Sheet Widths:</b>	variable from 4 to 10 in. (approx. 101 to 254 mm), including 1/2 in. tractor strips

**Stack Limit:** up to 15 in. (approx. 380 mm) in height or about 2000 sheets of 24 lb bond paper

## FLOOR MODEL STACKER SPECIFICATIONS

**Width:** 20 in. (approx. 508 mm)

**Length:** 37 in. (approx. 940 mm)

**Height:** 30 in. (approx. 762 mm)

**Weight:** 43 lb (approx. 20 kg)

**Shipping Dimensions:** 22 x 26 x 33 in. (approx. 560 x 660 x 840 mm)

**Shipping Weight:** 55 lb (approx. 25 kg)

**Power Supply:** 12 vdc at 800 ma. One of two power supplies is shipped with the stacker: either a UL/CSA, 120 vac, 60Hz, plug-in power supply, or a 230 vac, 50Hz, in-line power supply with a TÜV power cord

**Power Consumption:** not more than 10 w

## UNPACKING & INSTALLATION

You will need a utility knife for unpacking the container and a small, flat-blade screwdriver to fasten cable connectors.

1. Inspect shipping container for damage. Report damage to carrier *immediately*.
2. Stand shipping container upright.
3. Use a utility knife to remove one side of the container.
4. See Caution below, then move contents to installation site.

---

### **! CAUTION !**

**If you use a lift truck, only lift along bottom rails of the stacker. Do not use a lift truck after plastic strap has been removed.**

---

5. Remove plastic stretch wrap.
6. Remove accessories box. Also, remove bubble package resting on refolding deck. Check contents of box and package against the following illustration.
7. Cut plastic strap holding cardboard pad to bottom of deck.
8. Use the screwdriver provided to remove two screws (with nylon washers) holding printer stand to refolding deck. Lift off stand and then re-install screws and washers to deck.

9. Lift refolding deck off cardboard pad. Save all packing materials.

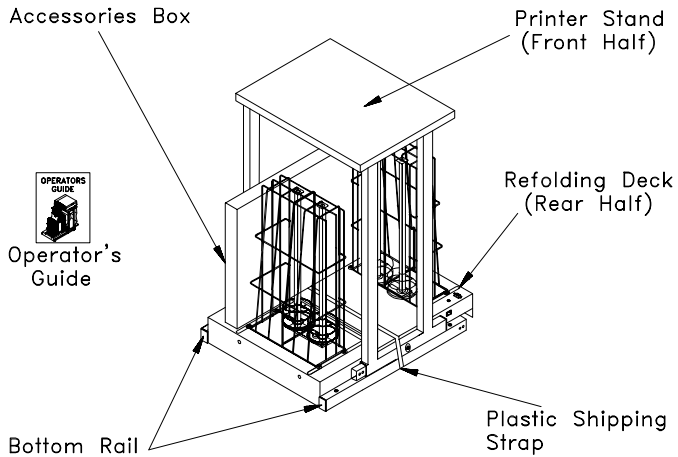

Accessories

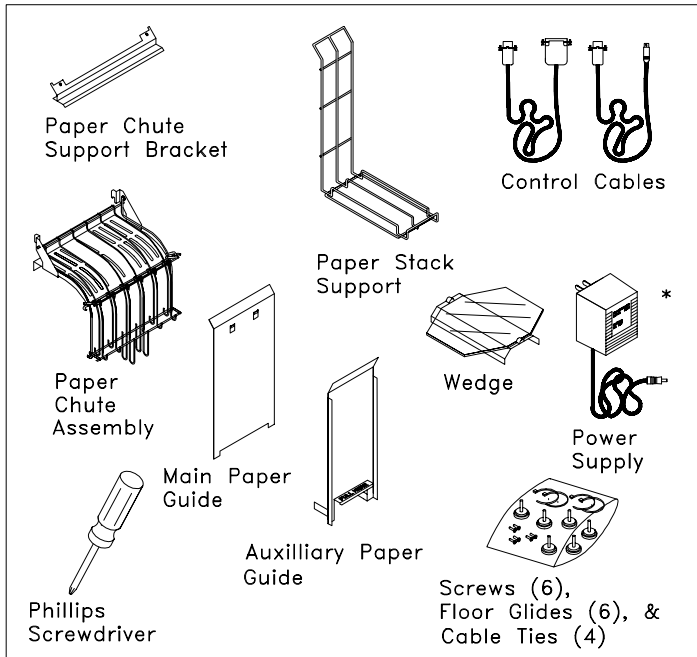

LB0-C5

\* UL/CSA, 120 vac, plug-in power supply is shown here. A 230 vac, in-line power supply is available.

## ASSEMBLY

1. Move refolding deck and printer stand onto a hard, flat surface.
2. Position U-channels of printer stand rails just opposite open rails of refolding deck, as shown in the next illustration.

---

***NOTE:** It is possible to install the deck backwards. Make sure you orient the deck, as shown in the illustration, so that the corner of the deck with the manual mode switch is located nearest the printer stand.*

---

3. Insert channels of printer stand into rails of refolding deck so that two pairs of screw holes line up. (It may be necessary to temporarily loosen the four screws that secure the refolding deck to its rails.)
4. Secure the two halves of the stacker with the screwdriver and four,  $\frac{3}{8}$ -in.-long Phillips screws provided in the accessory box.
5. If necessary, retighten screws to resecure deck to its rails.

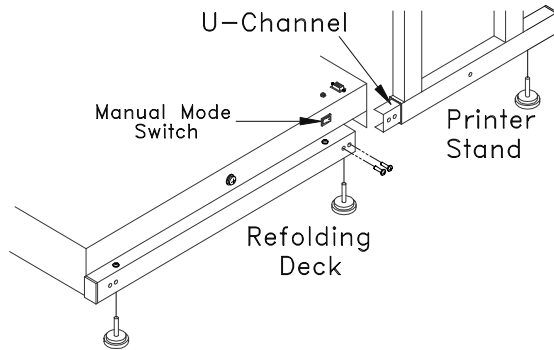

LB0-D3

6. Tilt this assembly and screw in floor glides near the ends and middle of the rails. Adjust the glides so that the stacker is stable.

---

**NOTE:** An optional set of six casters can be used in place of the floor glides.

---

7. Place the stacker in position and then place the printer on the printer stand. Also, check to see that the front of the printer is parallel to the front edge of the stand.

The feet on the printer must rest in the indentations provided in the stand.

8. Do one of the following:
  - If you have a 24 page per minute LaserMatrix printer, proceed to Step 9.
  - If you have a 16 paper per minute

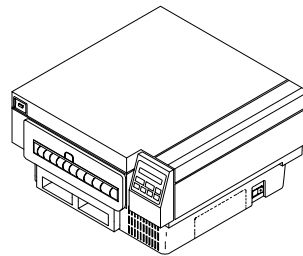

PB0-A

**24 Page Per Minute  
LaserMatrix Printer**

LaserMatrix printer,  
proceed as follows:

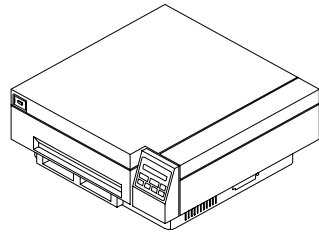

PB0-C

### 16 Page Per Minute LaserMatrix Printer

For a 16 page per minute printer, use the two remaining screws (the shorter,  $\frac{1}{2}$ -in.-long, screws) to fasten the paper chute support bracket to the printer's plastic fuser cover, as shown in the illustration on the right.

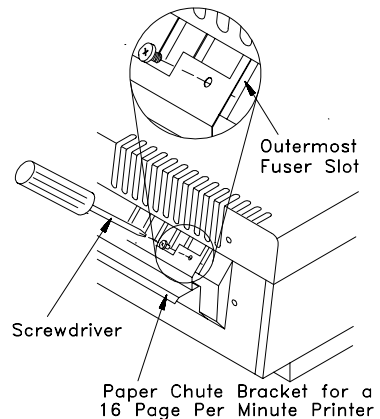

LB0-E3

When doing so, be sure to hold bracket firmly against the printer. Make sure the screws thread into the outermost slots of the fuser cover.

9. Install the paper chute assembly onto printer:
  - a. With the top cover of the printer closed, insert hooked tabs of paper chute support into outermost

slots at the top of the printer's cover, as shown in the next illustration.

For a 16 page per minute LaserMatrix printer, the bail on the paper chute should rest on the paper chute support bracket.

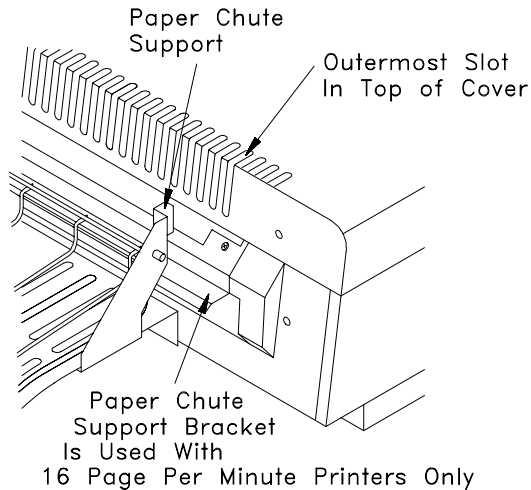

LB0-G1

- b. Pivot the paper chute slightly and then lift the free end of the pivot arm, which is attached to the paper chute, and insert it into slotted bracket on printer, as shown in the next illustration.

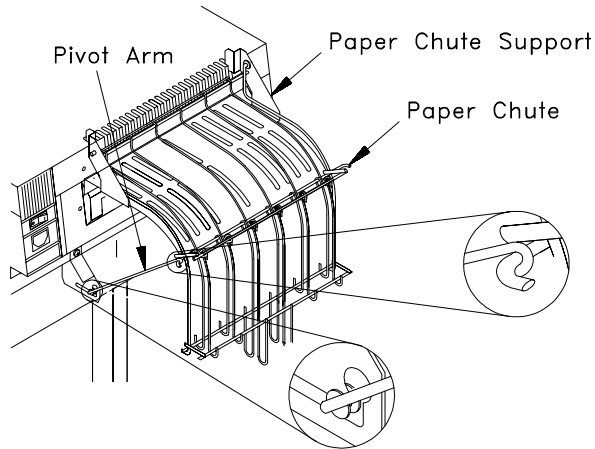

LB0-F2

- c. Slowly open top cover of printer to check that this paper chute assembly is securely in place.
10. See Caution and Note below before installing control cable, as follows:

---

### **! CAUTION !**

**Do not use a control cable if your printer requires a paper motion sensor for automatic operation. (See the table on Page 29.) If you use a control cable where the table on Page 29 specifies a paper motion sensor, you may damage printer electronics.**

---

***NOTE:** Two types of control cables are provided with the stacker for use with LaserMatrix printers built after May 23, 1994. With all other printers, use either the manual mode switch, shown in the illustration on Page 13, or install a paper motion sensor (Part No. LM1000A119). The paper motion sensor, like the control cables provided, turns on the stacker only when the printer prints. For*

*more information, see Parts & Accessories, beginning on Page 27.*

---

a. Do one of the following:

- For a 24 page per minute printer, connect the cable with the round, 6-pin DIN connector to printer's back panel, shown in the following illustration:

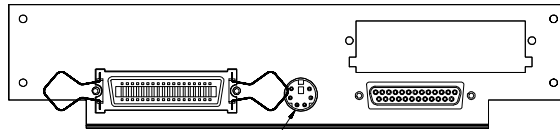

6-Pin, DIN Connector on Back of  
24 Page Per Minute Printer

PB0-B

- For a 16 page per minute printer, connect the cable with the D-shaped, 25-pin connector to the printer's back panel, shown in the following illustration:

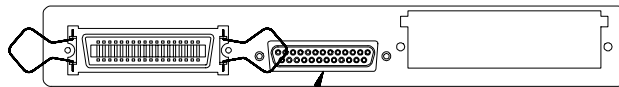

25-Pin, Serial Interface Connector  
on Back of 16 Page Per Minute Printer

LB0-I2

b. Connect the 9-pin end of the control cable to the D-shaped, 9-pin control connector on the refolding deck.

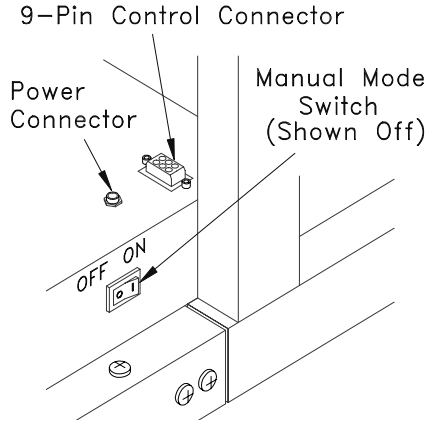

LB0-H1

**NOTE:** The 25-pin connector on the printer is the serial interface connector. If your 16 page per minute LaserMatrix printer uses the serial port for data input, you must connect a serial adapter between the computer and stacker cables and the 25-pin connector on the printer. If you require a serial adapter (Part No. LM1000A121), contact Output Technology by voice or fax. See the phone numbers at the front of this publication. Or make your own from the wiring diagram below.

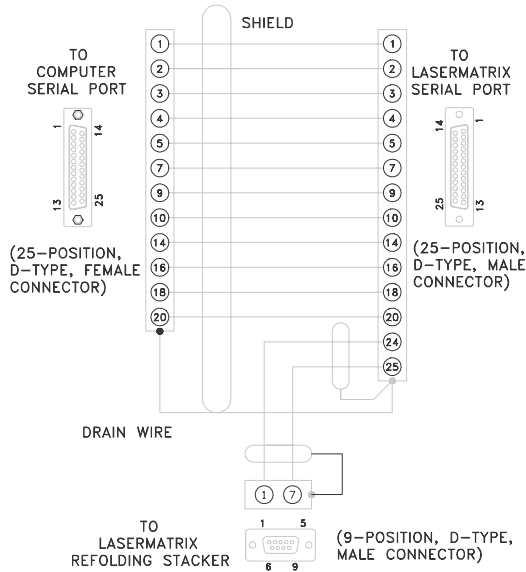

**Serial Adapter Wiring Diagram**

LB0-P3

- c. Tighten screws on both connectors to secure cable.
  - d. Make sure manual mode switch on refolding deck is off, as shown in the illustration on Page 13.
11. Insert connector on power supply cable into receptacle on refolding deck. Connect power supply to a suitable receptacle.

If your power source is other than 120 vac at 60Hz or 230 vac at 50Hz (or your receptacle is other than a NEMA 5-15 or a CEE 7/7, as shown in the following illustration), you will need to purchase a class 2, regulated 12 vdc, power supply. The power supply must be capable of supplying 12 vdc at a minimum of 800 ma to the stacker via the type of connector shown in the following illustration.

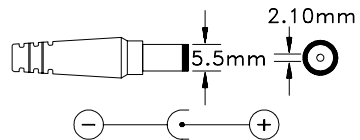
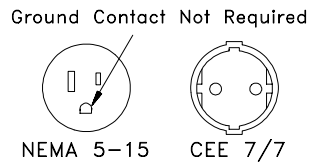

J1

LB0-

12. If desired, use supplied cable ties to fasten control and power cables to legs of stacker.

13. Test manual mode by toggling the manual mode switch on the refolding deck.

Both pairs of refolding coils should turn.

14. Test automatic mode for a LaserMatrix printer, as follows:
  - a. Turn on LaserMatrix printer.
  - b. Print a one-page print job.<sup>1</sup>

When the LaserMatrix printer begins to print it will start the stacker. The stacker will stop when the LaserMatrix printer stops printing. If it doesn't start and stop automatically, you may need to install a paper motion sensor for automatic operation. See *Parts & Accessories, Page 27*.

15. Slip the main paper guide onto the paper stack support, as shown in the following illustration.
16. Slide this assembly, the paper stacker, between support channels on refolding deck.

---

***NOTE:*** *The paper stacker assembly may be installed for either right- or left-side access, whatever's convenient.*

---

---

<sup>1</sup> For example, to print a summary page, be sure the printer is off line, then press the **MENU** key. After the printer displays "Print: Summary," press **STORE** to print.

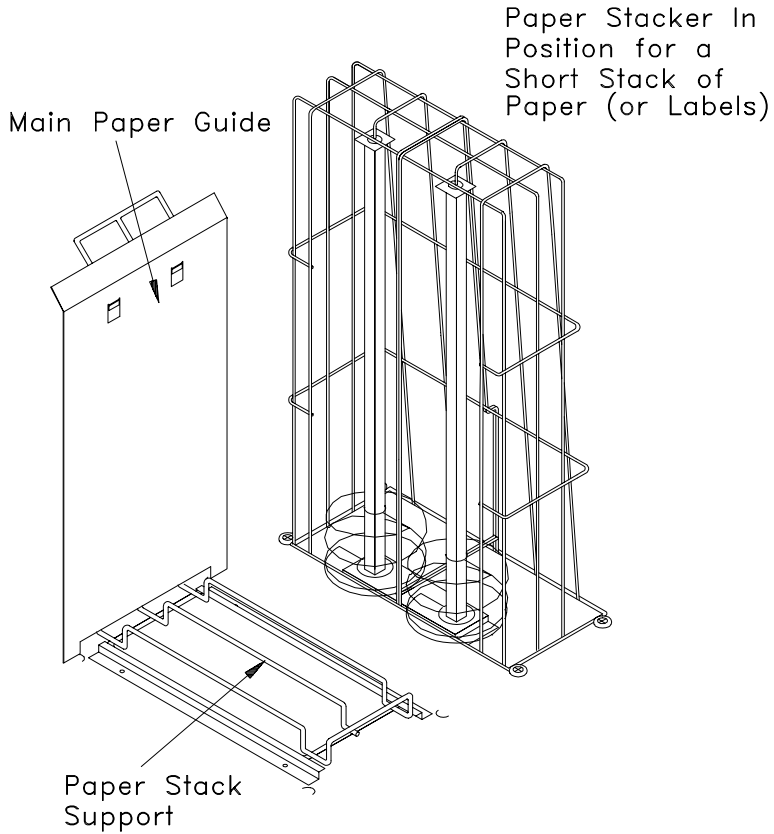

LB0-K

## SETUP

### ***For a Short Stack of Paper (or Labels) —***

You're all set. Use the paper stacker as shown in the previous illustration. Continue with "Operation," Page 20.

### ***For a Tall Stack of Narrow Paper (or Labels) —***

An auxiliary paper guide is provided to help control tall stacks of paper or labels.

To install, slip auxiliary paper guide into paper stacker channels so that it rests on top of paper stack support. Position the auxiliary paper guide so that the distance between the two sheet metal paper guides is  $\frac{1}{4}$  in. (approximately 6 mm) more than the width of the fanfold paper or labels.

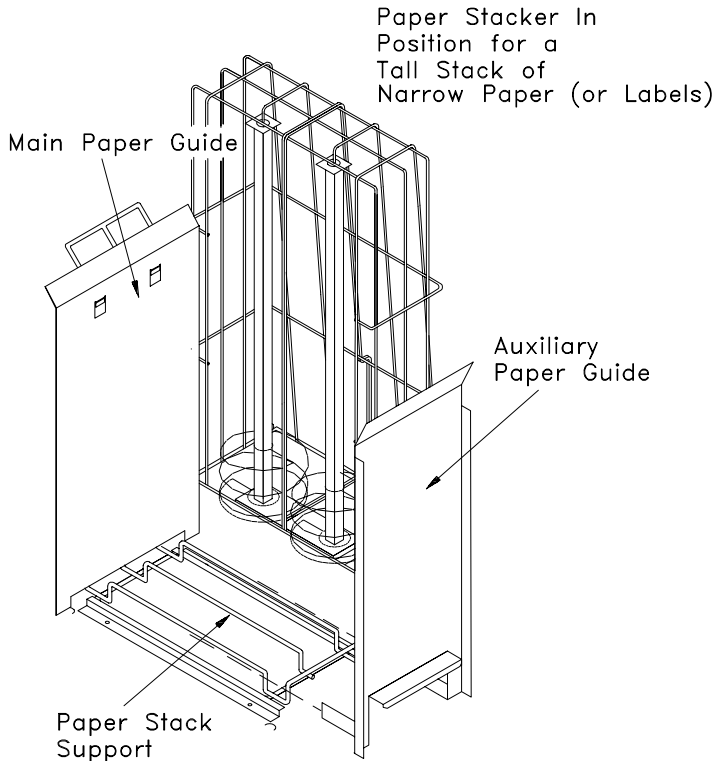

### **For a Full Box of Full Width Paper —**

Fanfold paper tends to curl at the bottom and top perforation folds. A wedge is supplied to counter this curl so that the paper stacks evenly. The flexible platform attached to the wedge allows the refolding coils to capture the first few sheets of paper, which would otherwise miss the coils because of the wedge. The flexible platform will bend down and out of the way as the paper stack grows.

The auxiliary paper stack guide helps to control tall paper stacks.

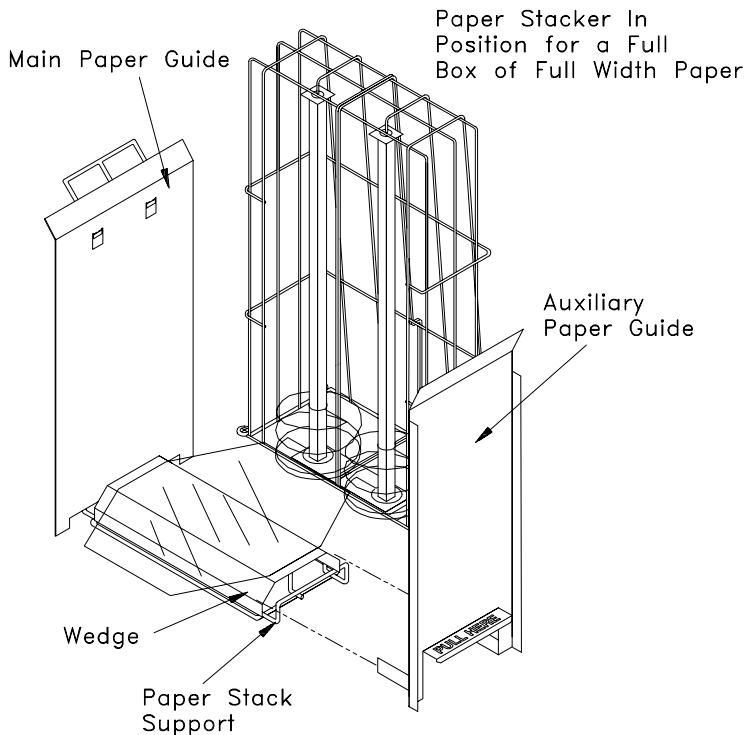

To install the wedge and auxiliary paper guide —

1. Snap wedge onto wireform of paper stacker.

It's easiest if you snap in one side first and then slightly compress the wedge to fit the other side.

2. Push the wedge against the main paper guide.
3. Slip auxiliary paper guide into paper stacker channels so that it rests on top of paper stack support. Butt the auxiliary guide against wedge.

With all parts assembled, the distance between the main and auxiliary paper guides should be about  $9\frac{3}{4}$  in.

4. Continue with "Operation," which follows.

## OPERATION

1. Adjust position of paper stacker so that the face of the main paper guide is approximately at edge of paper.
2. Now slide refolding units so that indicator marks at bottom of units point to the proper perf-to-perf form length marked on the deck.

The refolding units are mounted on a rack and pinion mechanism so that they move as a unit. When you adjust one, the other automatically adjusts to the same complementary position.

---

**NOTE:** *The positioning of the refolding units is critical for fault-free performance.*

---

3. Check that the four coils are at the bottom of their risers.

The top caps of the risers contain two plastic barbs to capture the coils and suspend them so that you can easily remove the print job.

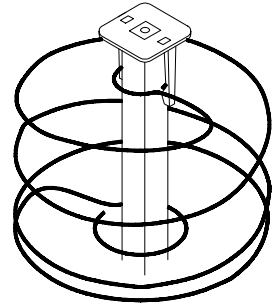

---

**NOTE:** Make sure to lower coils again after every print job so that they're ready for the next print job.

---

LB0-N

4. Open bail of paper chute.
5. Make sure that the paper will stack on the stacker in the same way it is in the box. To do this, mark an "X" on one of the horizontal out-fold perfs at the paper entrance to the printer, as shown in the following "Before" illustration, and then use the printer's control panel to form feed that fold through the printer.

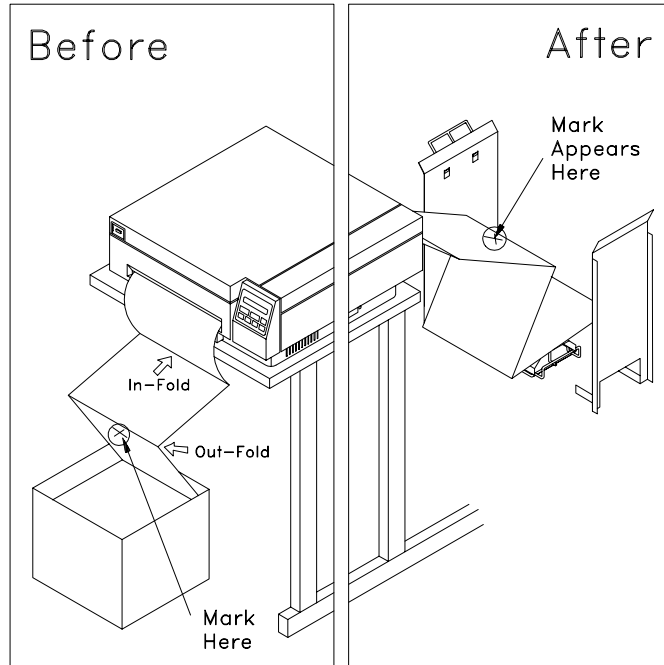

LB0-M1

6. At output of printer, make sure that paper feeds through paper chute and then close the bail.
7. Again, use the printer's control panel to advance the paper. Continue until out-fold perf with mark is at bottom of stacker.
8. Make sure the mark you made at the out-fold perf is not lapped over, as would be the case of an in-fold perf. (See the "After" illustration.)

9. Adjust paper stacker, if necessary, so that paper falls in a straight cascade from the paper chute to bottom of stacker.

The paper should be centered between the two pairs of coils. Stacking works best if the paper stack is started about  $\frac{1}{8}$  in. (approximately 3 mm) from the paper guide(s), as shown in the following illustration.

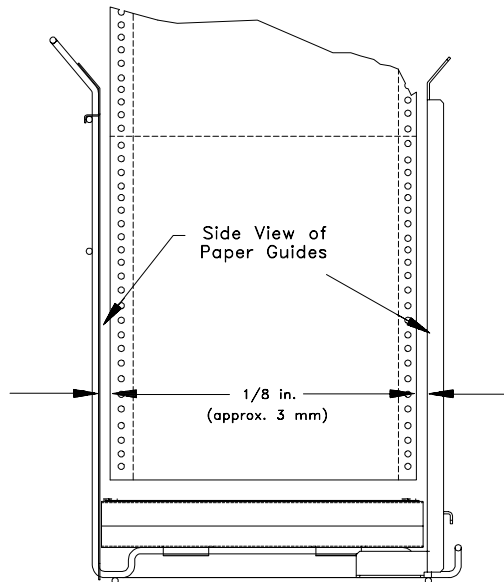

LB0-T

10. Begin printing.
11. If necessary, re-adjust paper stacker and/or refolding unit. The paper should not drag or hang up on sheet-metal paper guide(s), especially when you just begin a stack.

---

**NOTE:** *Starting the stack  $1/8$  in. from the guides is important if you plan on a tall stack, and especially when using lower-quality paper. The perfs of some fanfolded paper are not always squared well with each other and so, as the stack grows, it may tend to lean a little. If this causes a problem, we recommend a different brand of paper<sup>2</sup>.*

---

12. When print job is done and you wish to retrieve your printing, advance the last printed page past the paper chute and then separate at the perf.
13. If you used the auxiliary paper guide, slide it out of the deck channels.
14. Lift the refolding coils to the tops of their risers.
15. Use the handles on the paper stack support to slide out and transport the print job.

Don't use the flexible platform attached to the wedge of the paper stacker for carrying the print job. If you do, you might spill the paper stack. Use the built-in handles on the paper stack support.

---

<sup>2</sup> If stack-lean interferes with unattended performance, check for bad perforation alignment. To test for perforation misalignment, turn the box of paper around on the next print job and check if the stack tends to lean in the opposite direction. If it does, change brand names. We recommend our own brand of paper (Part No. LM1000C112) which is manufactured to exacting tolerances for consistent performance.

16. After removing the stack of paper, don't forget to release the coils so that they're ready for the next job.

The LaserMatrix Floor Model Stacker will hold more than the tallest box of continuous form paper. If you happen to overfill the stacker with paper from more than one box, the coils will compress at the top of their risers. Although this won't harm the stacker, you may find it inconvenient when removing the print job. If you compress the coils to their limits, the rest of the print job will not stack properly.

## MAINTENANCE

### *Cleaning*

- For Paper Dust, a large, soft, floppy brush works well.
- For Smudges, Dirt, etc., use a damp (not dripping) cloth with or without a little soap. You can use a mild household cleaner like **409**<sup>3</sup>. But don't allow water or other cleaner to seep into the power or control connector on the refolding deck, or into the drive mechanism of the refolding unit.

---

### **! CAUTION !**

**Don't use petroleum-based cleaners and solvents such as lighter fluid, paint thinner, etc., which can damage paint.**

---

---

<sup>3</sup> **409** is a brand name of The Clorox Company.

## ***Lubrication***

The LaserMatrix Floor Model Stacker is lubricated for life. Do not lubricate in any way.

## **TROUBLESHOOTING**

### ***When It Doesn't Run —***

Check the power supply and control cable.

### ***When Only One Pair of Coils Turns —***

One of the two motors has failed. Call one of the voice or fax phone numbers listed on the back of the title page.

### ***When It Doesn't Stack Right —***

- Check that the paper falls in a straight line from the printer to the stacker. Make sure the paper stack support is directly below and centered with the paper chute.
- In general, the stack should be centered front-to-rear and side-to-side among the four coils.
- Check that the paper is not being refolded in the wrong way. It should stack on the stacker like it was in the box.
- Use a better grade of paper. See Pages 27 and 28 for ordering paper from Output Technology.

## PARTS & ACCESSORIES

### ***Customer Replaceable Parts***

Customer replacement parts are listed below<sup>4</sup>. When you order by phone or fax (phone numbers are listed inside the front cover of this publication) have the serial number of your LaserMatrix Floor Model Stacker handy. The serial number appears on a label on the rim of the refolding deck. Also, have your Visa or MasterCard number and expiration date ready.

<b>Item</b>	<b>Part No.</b>
Paper Chute Support Bracket	001-00812-XX
Paper Chute Support	001-00745-XX
Paper Chute	001-00746-XX
Stack Support	001-00742-XX
Wedge (with flexible platform)	046-00878-XX
Main Paper Guide	001-00797-XX
Auxiliary Paper Guide	001-00808-XX
Control Cable for 16 ppm Printer	020-00185-XX
Control Cable for 24 ppm Printer	020-00208-XX
Paper Motion Sensor	LM1000A119
Power Supply (120 vac, 60Hz)	LM1000CK100
Power Supply (230 vac, 50Hz)	LM1000CK200
Adapter Cable for LM1000CK200	020-00016-XX
Operator's Guide	066-00452-XX
Set of 6 Casters <sup>5</sup>	LM1000A126

<sup>4</sup> Call for price.

<sup>5</sup> 2 locking, 4 nonlocking.

### ***Fanfold Paper (LM1000C112)***

Fanfold paper manufactured for Output Technology is optimized for use with the LaserMatrix printer and LaserMatrix Floor Model Stacker. The paper is white, 24 lb, 8<sup>1</sup>/<sub>2</sub> in. x 11 in., fanfold paper (2000 sheets) which stacks to a height of about 11 in.

### ***Paper Motion Sensor (LM1000A119)***

The paper motion sensor is not required on LaserMatrix printers manufactured after May 23, 1994. For these, the control cable connecting the LaserMatrix printer to the LaserMatrix Floor Model Stacker allows the LaserMatrix printer to turn on the stacker only when the printer is printing.

LaserMatrix printers manufactured *before* May 23, 1994 require a paper motion sensor (Part No. LM1000A119) for automatic operation. Also, the paper motion sensor is necessary for automatic operation on other brands of continuous form laser printers.

The paper motion sensor bolts to two threaded studs on the underside of the paper chute support. A cable attached to the sensor is connected to the D-type connector on the refolding deck.

The table that follows lists part nos. of LaserMatrix printers that require a paper motion sensor for automatic operation. For the LaserMatrix printers, read the part no. on a label on the back of the printer, below the paper exit. The last two numbers of the part no. (XX) is the revision code for the printer.

## 16 Page Per Minute LaserMatrix Printer Paper Motion Sensor Effectivity<sup>6</sup>

LaserMatrix Printer (Part No.)	Is Paper Motion Sensor Required for Automatic Operation?	
	Yes	No <sup>7</sup>
048-00081-XX	all	
048-00082-XX	all	
048-00135-XX	all	
048-00136-XX	all	
048-00154-XX	up to 048-00154-13	048-00154-14 & on
048-00156-XX	up to 048-00156-10	048-00156-11 & on
048-00157-XX	up to 048-00157-12	048-00157-13 & on
048-00158-XX	up to 048-00158-09	048-00158-10 & on
048-00171-XX	up to 048-00171-09	048-00171-10 & on
048-00178-XX	up to 048-00178-09	048-00178-10 & on
048-00181-XX	up to 048-00181-06	048-00181-07 & on
048-00182-XX	up to 048-00182-06	048-00182-07 & on
048-00199-XX	up to 048-00199-00	048-00199-01 & on
048-00200-XX	up to 048-00200-00	048-00200-01 & above

<sup>6</sup> You don't need a paper motion sensor with a 24 page per minute LaserMatrix printer.

<sup>7</sup> You don't need a paper motion sensor with these 16 page per minute LaserMatrix printers.

